

Weld-In Venturi Nozzle EDV 800

Application

Venturi nozzles are used as flow elements for flow measurement of aggressive and non-aggressive gases, steam and liquids.

Design

Weld-in venturi nozzles are mainly used for high pressure, high temperature applications, especially in power plants.

They consist of a rounded inlet section, a cylindrical throat and an outlet cone. The upstream pressure tapping is usually manufactured as a single bore. The throat pressure tapping usually consists of four bore holes which lead to a ring chamber or annular ring. For some applications it is recommended to design the throat tapping as a single bore.

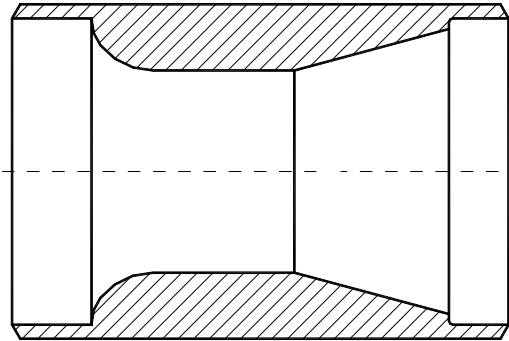

If needed, we can weld inlet and outlet pipe sections to the nozzle. These pipe sections are usually provided by the customer. The welding seams are mechanically processed in order to meet the surface roughness requirements of the respective calculation standard.

Advantages

Weld-In flow elements are the recommended choice for high pressure and high temperature appliances because they avoid any kind of leakage.

Compared to orifice plates, nozzles are recommended for appliances which require low pressure losses. At similar flow values nozzles need less differential pressure which results in less permanent pressure loss. The rounded inlet profile is less susceptible to erosion in comparison to the sharp edge of an orifice plate. Hence, nozzles achieve higher service life times.

Measuring Uncertainty

between 1,2% - 1,8% of the discharge coefficient C, depending on the application

Pressure Loss

The pressure loss depends on the diameter ratio β (d/D) and amounts to approx. 5 - 20% of the differential pressure.

Nominal Diameter (ISO 5167)

DN 50 to DN 500 / 2" to 20" (other sizes are available upon request)

Pressure Rating

PN 6 to PN 400 / 150# to 2500# (ASME)

Connection Type

Weld preparation according to EN ISO 9692 (DIN 2559), ASME B16.25 or customer standard.

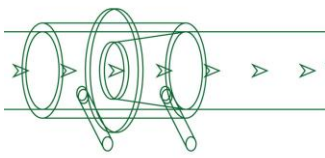

Installation Length „L“

The installation length depends on the diameter ratio β which needs to be calculated based on the respective process conditions. The following table presents an overview of typical installation lengths for an average diameter ratio β (d/D) of 0,6 and a pressure rating of PN 160.

Nominal Diameter DN	Installation length [mm]
50 / 2"	120
65 / 2,5"	140
80 / 3"	160
100 / 4"	200
125 / 5"	230
150 / 6"	260
200 / 8"	320
250 / 10"	400
300 / 12"	450
350 / 14"	500
400 / 16"	600
450 / 18"	650
500 / 20"	700

Bore Diameter "d"

The calculation of the bore diameter is based on the supplied process data. All relevant standards and regulations will be considered. The calculation is part of the scope of supply.

Pressure Taps

Pressure taps are designed according to customer requirements. Typical tap designs are:

- plain ends for fittings
- butt weld ends
- threaded ends
- flanged ends

The typical tapping length is approx. 100 mm.

Marking

Tag no. of flow element
Pressure rating "PN"
Pipe inner diameter "D"
Bore diameter "d"
Material, direction of flow and tagging
of pressure tappings with "+" and "-"

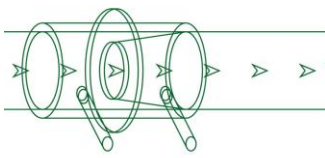

Materials

The following table shows a selection of typical materials utilized for weld-in nozzles. The material is chosen based on process medium, pressure and temperature. The pressure tap material is selected to be equivalent to the pipe material.

Venturi nozzle material	Description	DIN material no.	ASTM / UNS
non-alloy steels	P 250GH (C22.8)	1.0460	~A105
	A105	~1.0432	A105
heat resistant/alloys steels	16Mo3	1.5415	A182 Gr. F1
	13CrMo45	1.7335	A182 Gr. F11
	10CrMo910	1.7380	A182 Gr. F22
	15 NiCuMoNb 5	1.6368	-
	X10CrNiMoNb91	1.4903	A182 Gr. F91
stainless steels	X2CrNiMo17-12-2	1.4404	316L
	X6CrNiMoTi 17 12 2	1.4571	316Ti
high corrosion-resistant alloys	Hastelloy C276	2.4819	N 10276
	Monel 400	2.4360	N 04400

Example Designs

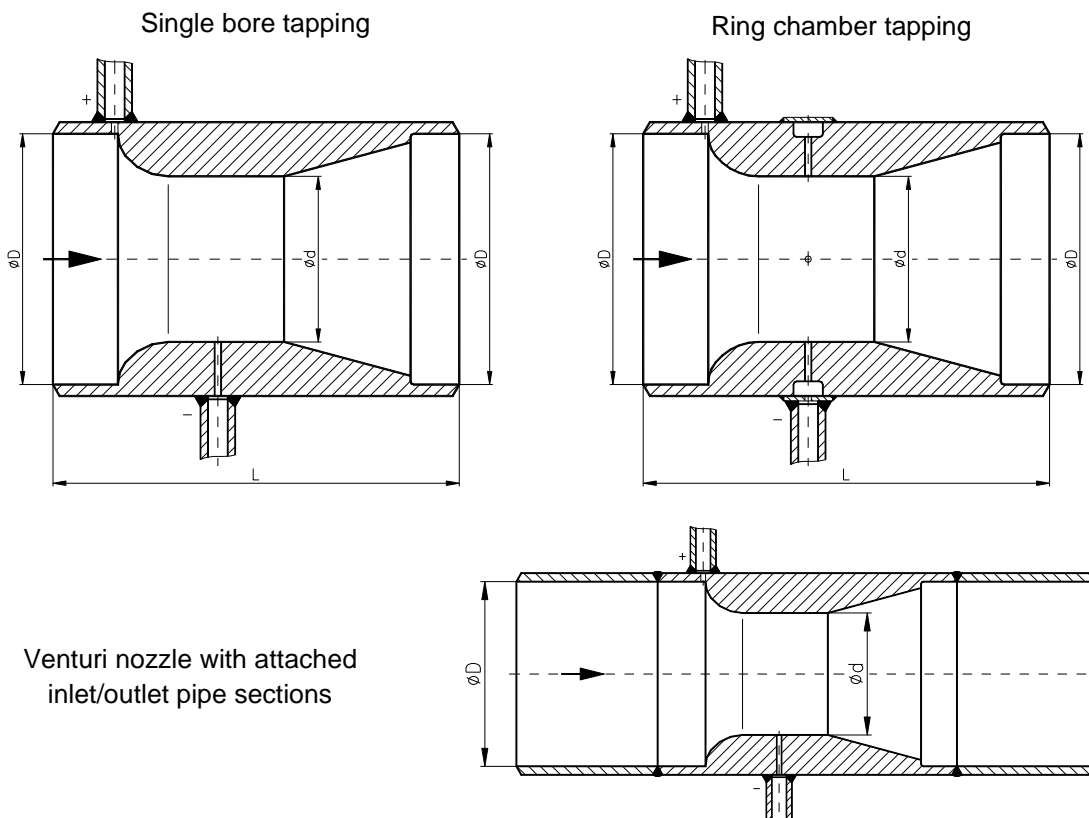

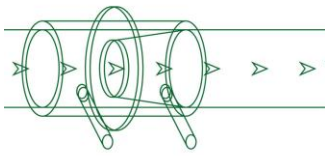

Installation

To be welded to pipes on construction site.

Quality Control

Manufacture and Test work is done according to the relevant codes and standards such as AD 2000, EN 13480, ASME Codes (without stamp) or customer specifications.

Inspection certificates according to EN 10204 3.1 and 3.2 are furnished if ordered. Special inspections are available upon request.

Accessories

Instrument valves, condensate pots, manifolds, mounting accessories can be included for additional charges.